

Aufgabe 1

Wo standen Tim und Tina, als sie das Foto gemacht haben?
Kreuze die Stelle auf dem Stadtplan an.

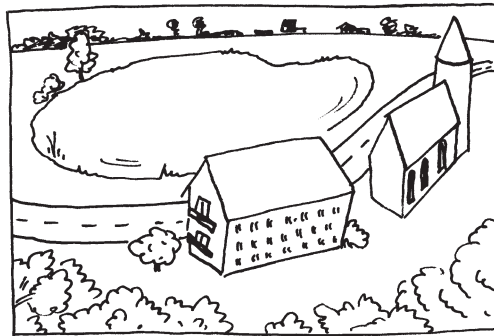
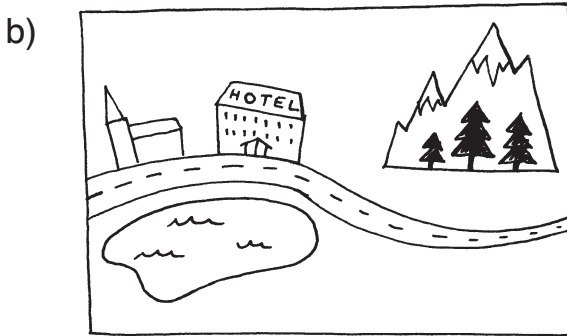
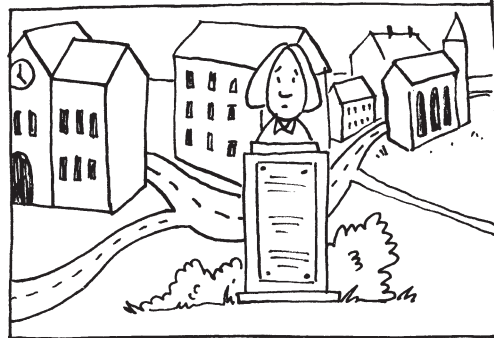
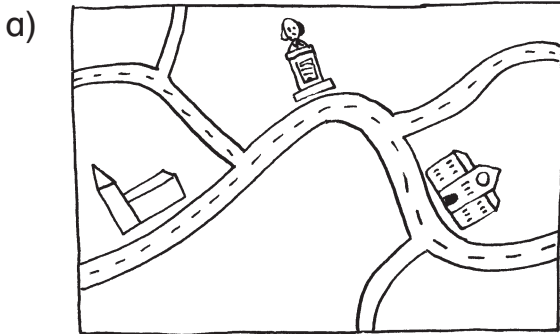

Aufgabe 2

Ordne die Fotos in der Reihenfolge, in der sie geknipst wurden. Nummeriere die Fotos.

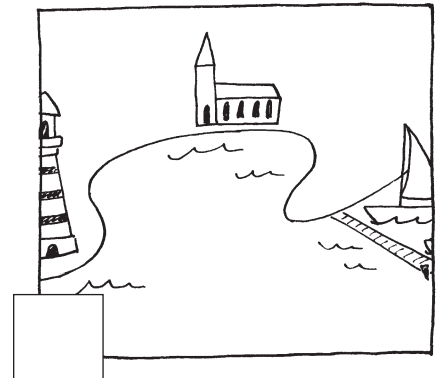
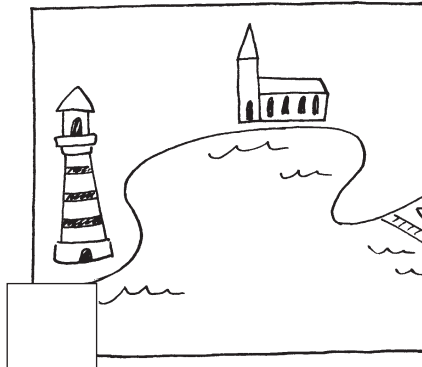
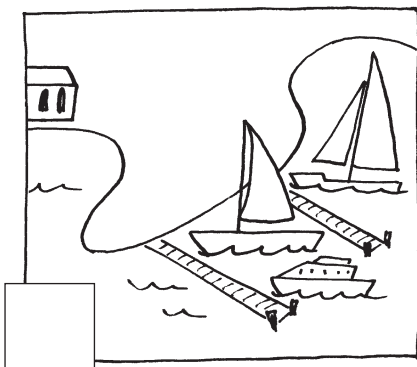
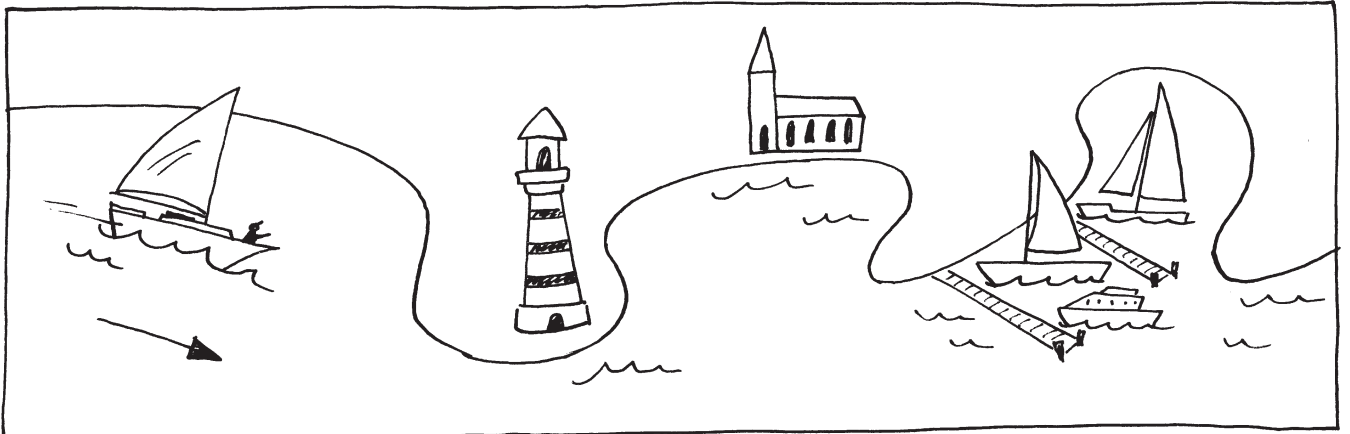

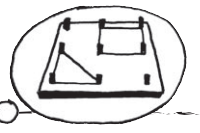

Aufgabe 1

Kontrolliere, ob die Figuren wirklich achsensymmetrisch sind.
Streiche die falschen Bilder durch.

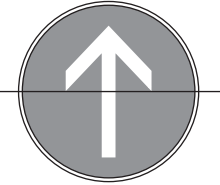
a) 

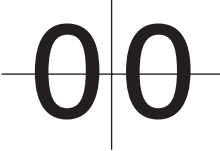
b) 

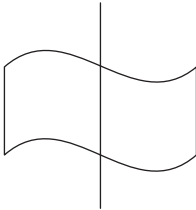
c) 

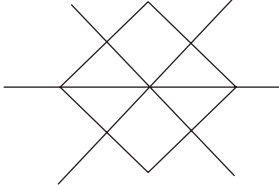
d) 

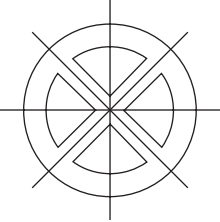
e) 

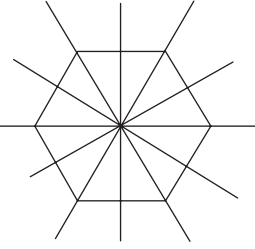
f) 

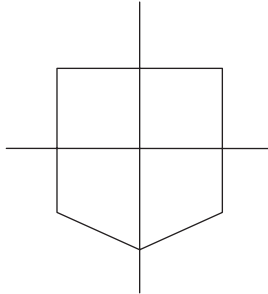
g) 

h) 

Aufgabe 2

Denke dir eine Figur aus mit ...

a) ... einer Spiegelachse.

b) ... zwei Spiegelachsen.

c) ... drei Spiegelachsen.

d) ... vier Spiegelachsen.

